

Nesting Technology with High-End Format

# DYNESTIC 7521



PRODUCTIVITY AND PRECISION



# Superior Productivity and Per

With the DYNESTIC 7521 portal machine HOLZ-HER has moved the limits for nesting technology to new dimensions. Technology at the highest level and equipment for large volumes have a model function.

- Welded moving stands in gantry design – particularly stable for maximum loads.
- Ground and hardened prismatic guides on all three axes (X, Y and Z-directions) guarantee exceptional precision.
- Basic dimensions – 3900 mm in X-direction, 2100 mm in Y-direction.

## Linear guides for maximum precision

A particular feature on the DYNESTIC 7521 are the high precision linear guides in reference quality on both sides of the portal. Equipped with their own rack-and-pinion drives all axes (X, Y and Z) are extremely easy to move. The linear guides are designed for extremely high precision and exceptionally long service life. In addition sliding shoes running on ball bearings and protected against dust ensure quieter operation.



Lubrication is accomplished over central lubrication bars. This supports the high precision of movement and ensures long component service life. Manual or automatic central lubrication (both optional) also minimises maintenance (Fig. shows manual central lubrication).



## More effective with charging feature

The workpiece is transported by the vacuum suction pads attached to the portal over the feed conveyor [Fig. 1] into the machine [Fig. 2]. After nesting it is moved to the discharge table conveyor by the discharge pushers [Fig. 3].

# formance

- Vacuum pumps with capacities of 250 m<sup>3</sup>/h, 500 m<sup>3</sup>/h (Option) and 750 m<sup>3</sup>/h (optional) provide high suction force for workpieces.
- DYNESTIC grid table, grooved, groove interval 50 mm, with one vacuum circuit.
- Large surface vacuum table with one vacuum circuit (standard) or more vacuum circuits (max. 8) (optional).
- Two stop fences at rear and one stop in field D (right).







## MACHINING HEAD

# Perfectly equipped for all requirements

Drilling, sawing, cutting, grooving – the DYNESTIC 7521 is equipped for true multi-function – perfect for rational production. The two prism guides in the Z-direction are hardened and polished to prevent even the slightest deviation.

- 24-spindle drilling head for variable hole patterns. In an L-shape; power 3 kW, 1000–5750 rpm.
- Horizontal drilling unit with 2 double spindles in the X-direction and 1 double spindle in the Y-direction; optional 3rd double spindle in the X-direction.
- 11 kW cutter unit with HSK 63F at space 1; alternatively 11 kW cutter unit at space 1.
- Sawing unit dia. 125 mm in X-direction (optional).
- High machining head feed rate for maximum productivity. X = 80 m/min, Y = 100 m/min, Z = 25 m/min.
- Effective evacuation unit integrated into machining head.
- Optional: Interpolating C-axis.



## Guaranteed for high efficiency

Variable equipment for rational machining. The traveling tool changer (optional) with 8, 12 or 18 tool spaces ensures short changeover times and high productivity.

# The control – absolutely clear and convenient

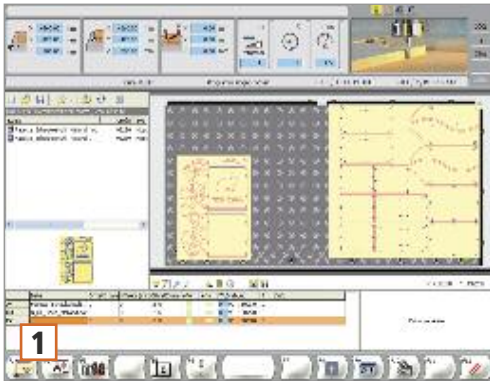

The HOLZ-HER machine control system is an integral part of the machine's design. The equipment package includes the CAMPUS Basic Bundle. This high performance software provides the prerequisites for effective machining and convenient operation [Fig. 1].

- 17"-TFT monitor or 19" monitor (optional)
- Complete graphic user surface
- Barcode interface
- Manual control unit
- Versatile import possibilities

## CAMPUS Basic Bundle

- NC-Hops editor provides for variable programming [Fig. 2].
- MT manager for simple tool management [Fig. 3].
- Workcenter ensures rational machine charging.
- The HOLZ-HER Nesting Software (optional) enlarged the package to a complete solution.

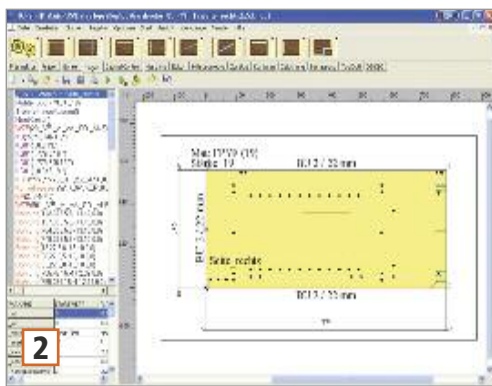

The open architecture of the machine software allows uncomplicated connection to all branch programs, design and CAD/CAM solutions

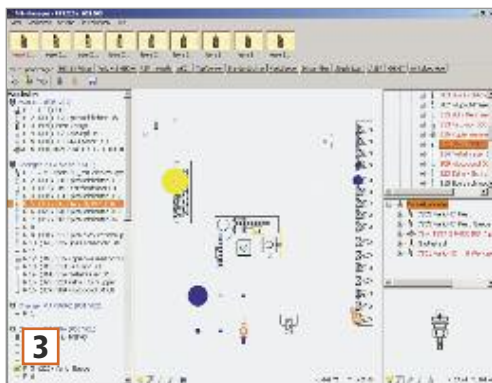

## HHPDE – network-compatible software for all HOLZ-HER Machines

All HOLZ-HER machines can be networked with each other. The digital workflow between the CabinetControl software, the saws, the edgebanders, the CNC machining centres and the HHPDE software (HOLZ-HER process data capture) ensures efficient production. HHPDE offers:

- Capture of all operating data,
- Time scheduling and calculation for order planning,
- Exact evaluation of job-related production data.

HHPDE is therefore the basis for efficient calculation.

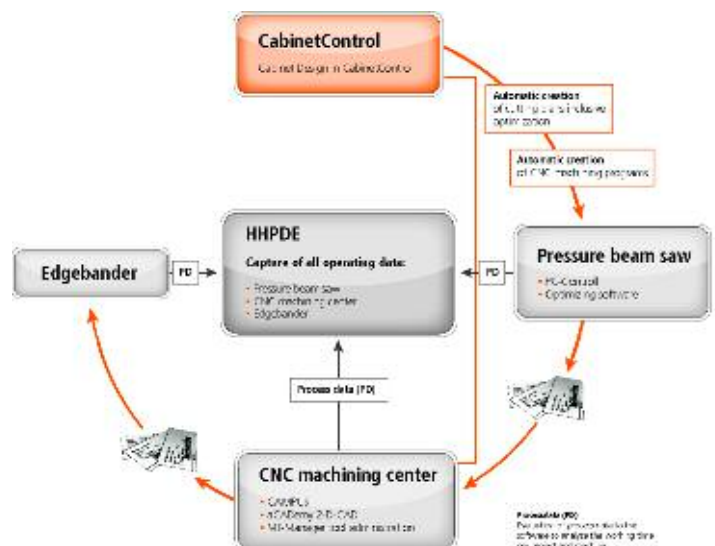



## Full utilisation for safety and reliability

- Front stops for horizontal holes (formatted work-pieces) (optional) [Fig. 1].
- Full utilization of working area, because grid reaches all the way to edge of table [Fig. 1].
- Circumferential cutting and horizontal machining with double drilling spindles over 2100 mm in Y-direction.
- Stops in X and Y directions [Fig. 1].
- Additional vacuum circuits available as options.
- Vacuum circuit can be switched from suction to blowing (optional).

**New: optional vacuum suction pads**

## For rational production

Large surface vacuum table with one vacuum circuit (standard) or more vacuum circuits (max. 8) (optional) [Fig. 2].

## Safety and Productivity

- An integrated light grid guarantees maximum safety during operation [Fig. 3, see at right].
- Single field foot mat (optional).
- A 3-field safety foot mat (optional with 2-field machining) opens the way to considerably increasing performance and efficiency.

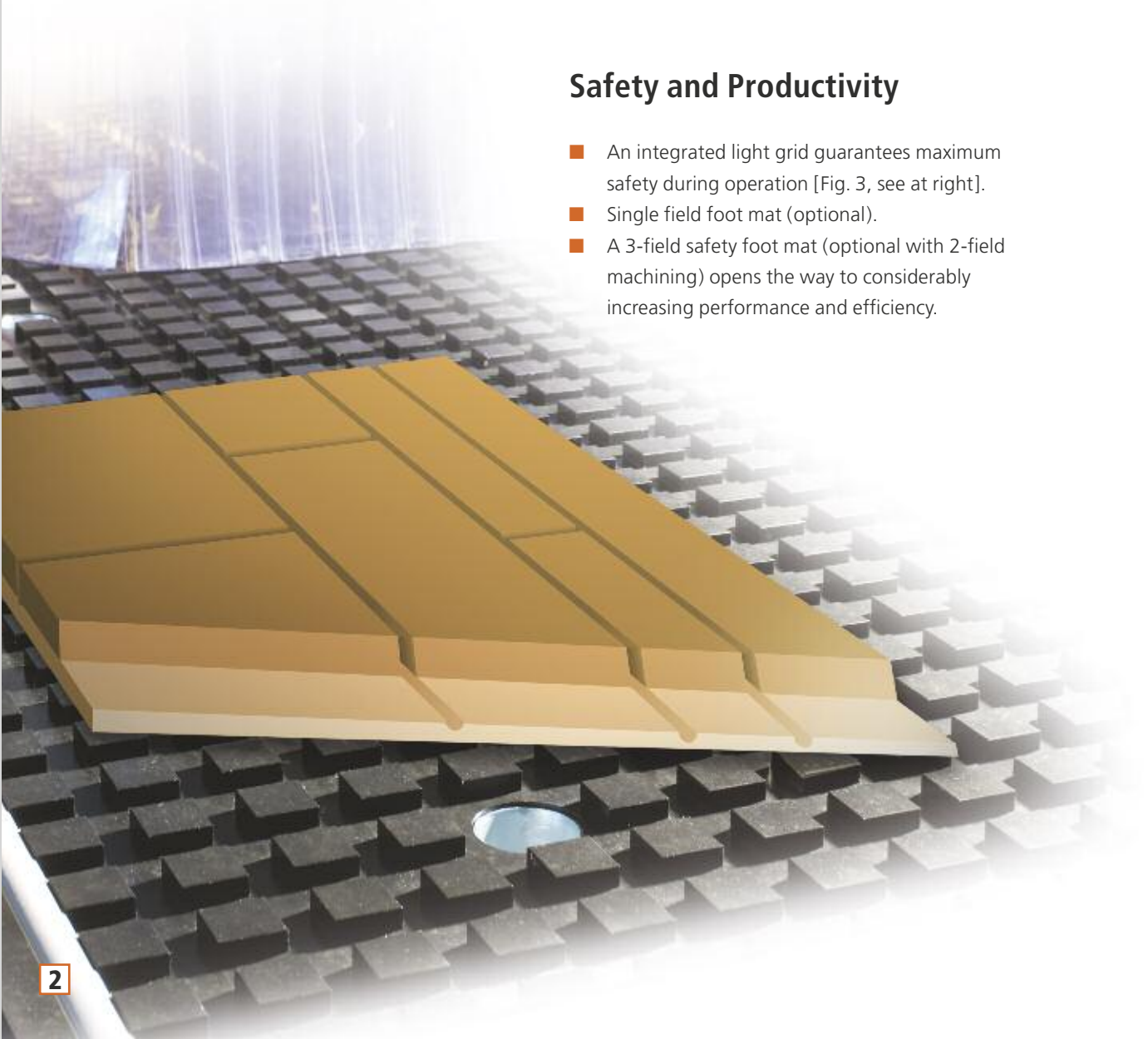



## Machining head

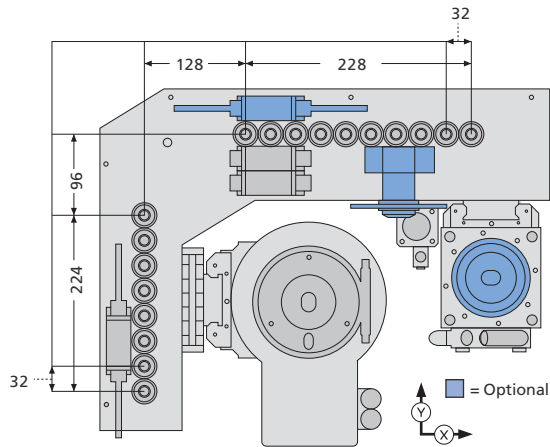

## Z-axis

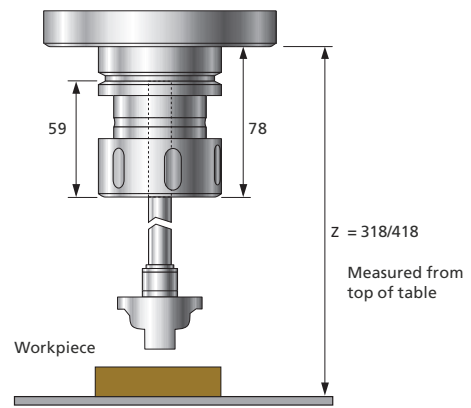

## Displacement paths

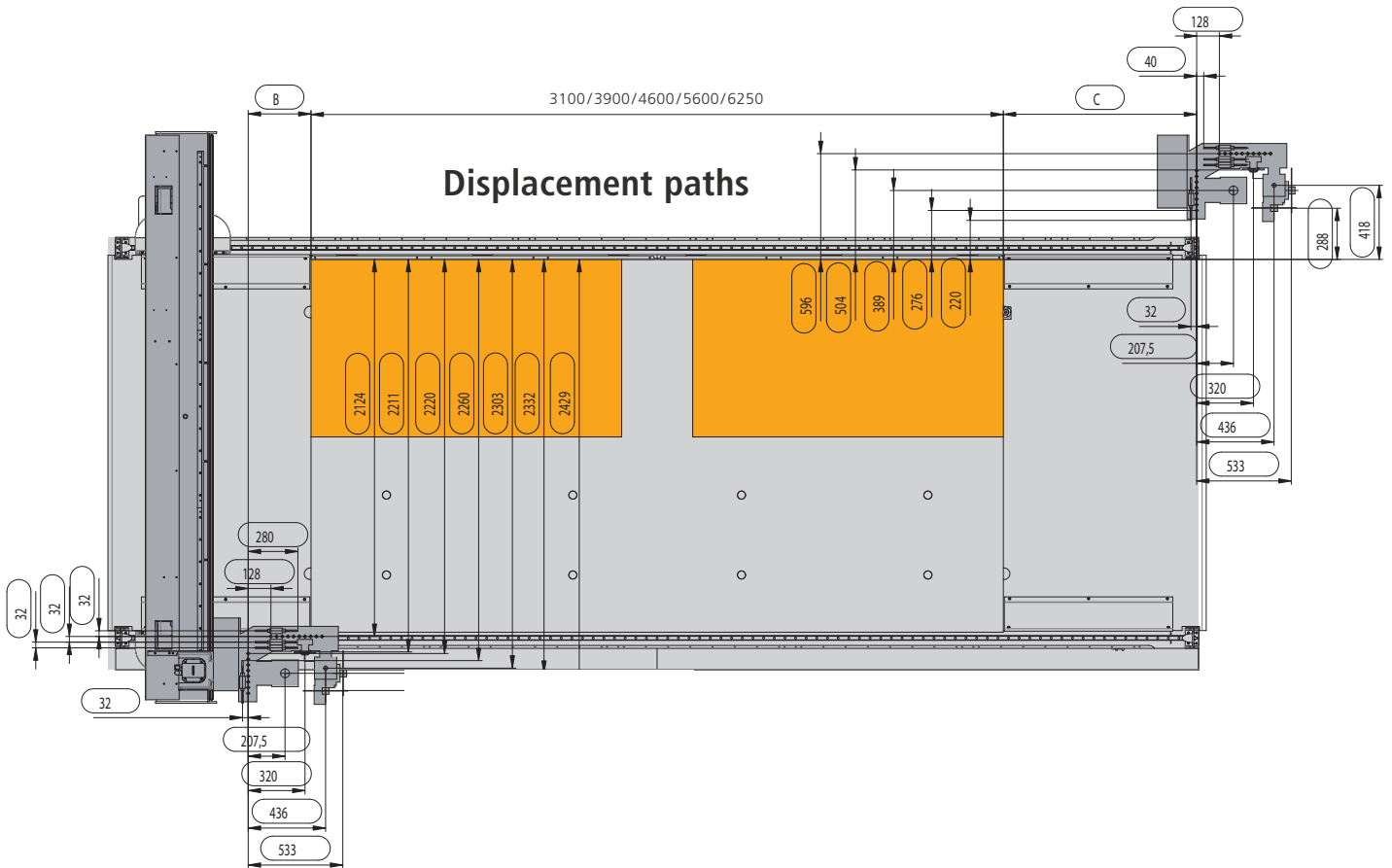

## Switch cabinet on right-hand side of machine

Dimensions (mm)	A	B
DYNESTIC 7521 10.6	7770	7210
DYNESTIC 7521 12.6	8550	8010
DYNESTIC 7521 15.6	9300	8710
DYNESTIC 7521 18.6	10200	9610
DYNESTIC 7521 20.6	10900	10380

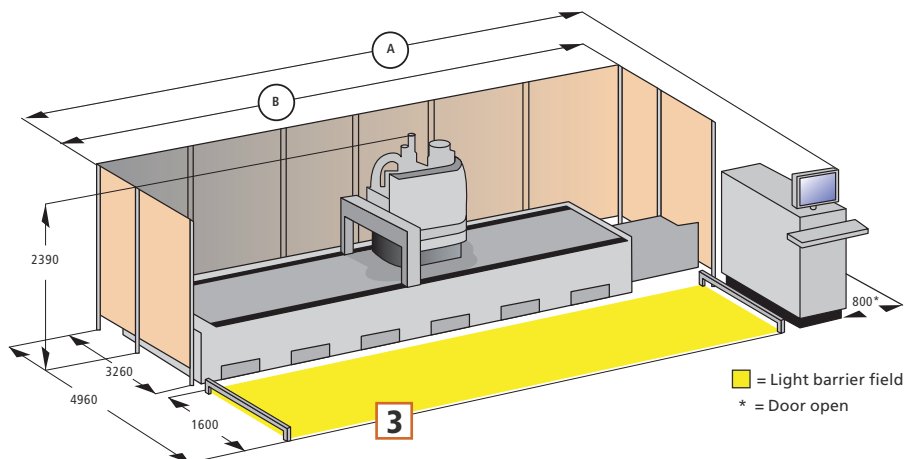

Product brochures and numerous  
videos can be found at  
[www.holzher.com](http://www.holzher.com)

## Technical data

	<b>DYNESTIC 7521</b>
<b>Machine</b>	
Weight (kg)	7570
<b>Drive, basic machine (design with two drives)</b>	
Max. displacement speed X-axis (m/min) (rack-and-pinion)	80
Max. displacement speed Y-axis (m/min) (rack-and-pinion)	100
Max. displacement speed Z-axis (m/min) (recirculating ball spindle)	25
Motor power, cutter unit type 7831 (kW) (S6) with HSK 63F (air cooled)	11
Rotational speed, cutter unit, type 7831 (rpm)	1000–24000
Motor power, cutter unit type 7832 (kW) (S6) with HSK 63F (water cooled)	11
Rotary speed, cutter unit, type 7832 (option) (rpm)	1000–24000
Motor power, cutter unit type 7834 (kW) (S6) with HSK 63F (water cooled)	16
Rotary speed, cutter unit, type 7834 (option) (rpm)	1000–24000
Motor power, drilling unit, type 7976 (kW)	3
Rotational speed, drilling unit, type 7976 (rpm)	1000–5750
<b>Electrical system</b>	
Connection voltage (Volts)	3 x 400
Mains frequency (Hz)	50/60
Power (depending on equipment) (kW)	20
<b>Compressed air</b>	
Operating pressure (bars)	6
Permissible limit pressure (bars)	8
Compressed air requirement (l/min)	300
<b>Dust extraction</b>	
Extraction rate (m <sup>3</sup> /h)	5300
Static vacuum (Pa)	2500–3000
Connector dia. (mm)	250
Dust extraction rate at connector (m/sec)	30
<b>Vacuum pumps for machining field</b>	
Vacuum pump (m <sup>3</sup> /h)	250
Vacuum pump (m <sup>3</sup> /h) (optional)	500
Vacuum pump (m <sup>3</sup> /h) (optional)	750

The technical data specified is intended for reference only. HOLZ-HER woodworking machines are subject to constant development and are therefore subject to modification without prior notice. The illustrations are therefore not binding. Some of the machines shown also contain special equipment not included as a standard feature. For clarity, some of the machines are shown without protective hood.

UK – HOLZ-HER 3256 45 – Printed in Germany/Imprimé en Allemagne  
Printed on: 29.07.2013 – First edition: 19.05.2008

Your authorized HOLZ-HER dealer



**HOLZ-HER GmbH**  
Plochinger Straße 65  
72622 Nürtingen  
Germany  
T +49 (0) 70 22 702-0  
kontakt@holzher.com  
www.holzher.com

**HOLZHER**  
A member of the WEINIG Group